



Tug of War Boots Guidelines

TWIF outdoor boot specifications

Heel: The heel shall be flush with the sole of the shoe – vertically down from the sole as seen from the back and side of the shoe. The front of the heel facing forward shall also be straight across, perpendicular to the sole and vertically down from the sole of the shoe.

The side of the heel impacting with the ground – the “cutting edge” – can have a tapered edge towards the front of the heel with a maximum protrusion of 15mm to the outside of the heel as measured from the vertical line from the sole. The other side of the heel must be completely flush with the sole and may not have any protruding feature. **The breadth of the heel must not exceed the breadth of the shoe.**

The maximum height of the heel, including a metal plate with a maximum thickness of 6.5mm, may not be more than 35mm from the bottom of the shoe. The 35mm includes the thickness of the sole. The length of the heel may not be less than one quarter or more than one third of the length of the shoe. See illustration below.

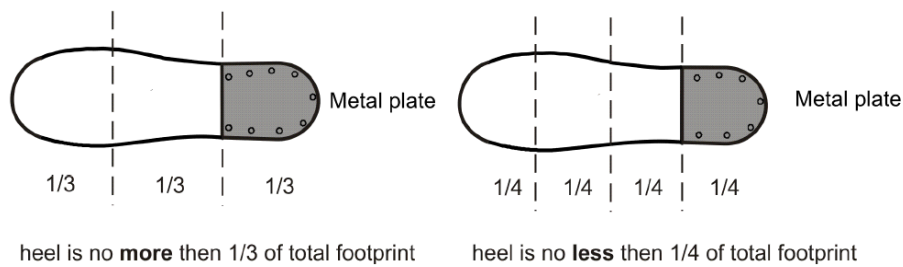

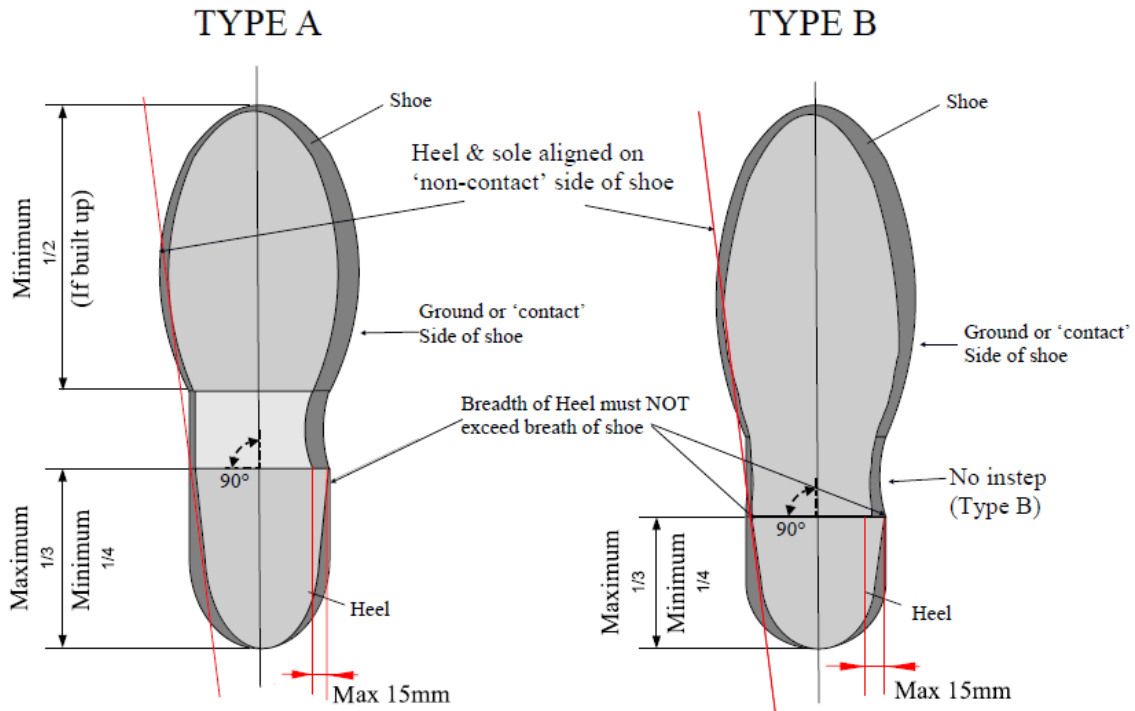

Sole Structure

View of bottom of the shoe with 'cut-out' instep

View of bottom of the shoe without 'cut-out' instep

The sole

“structure” (which includes the structure of the heel) may be metal but the sole plate must not be metallic, the minimum thickness of the non-metallic plate is 6.5mm. See illustration below.

Front part of the shoe: can be built up or left as it is. If not built up, the sole can be higher than the heel when viewed on a flat surface. In this configuration, the sole must be a minimum of 6.5mm higher than the heel. If built up, the front part of the shoe may not be less than half the total length of the shoe. The maximum height, including the sole may not be

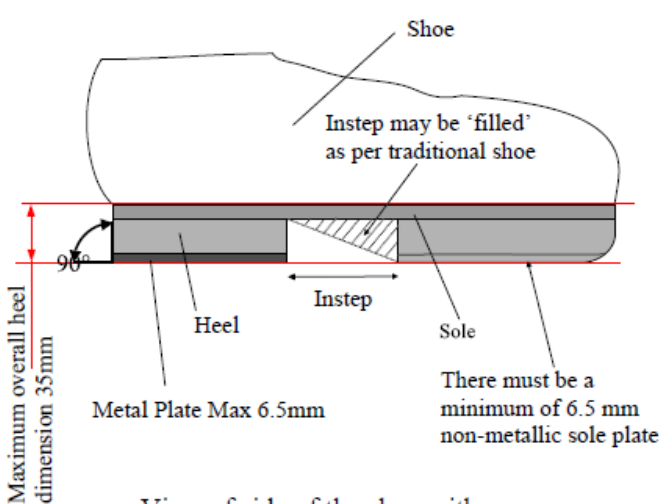

View of side of the shoe with 'cut-out' instep (Type A)

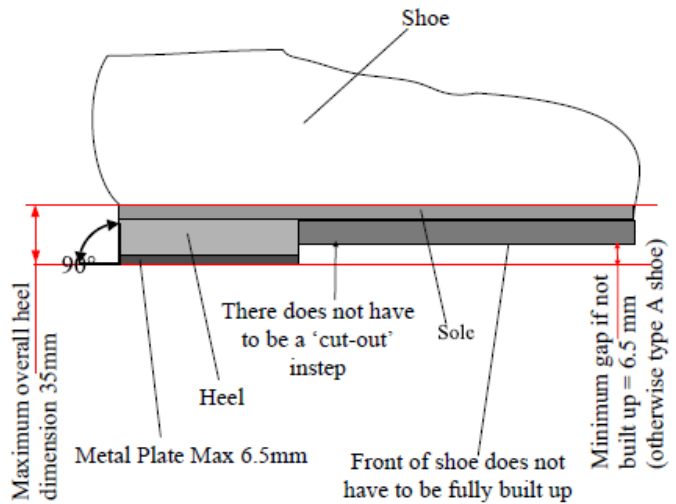

View of side of the shoe without 'cut-out' instep (Type B)

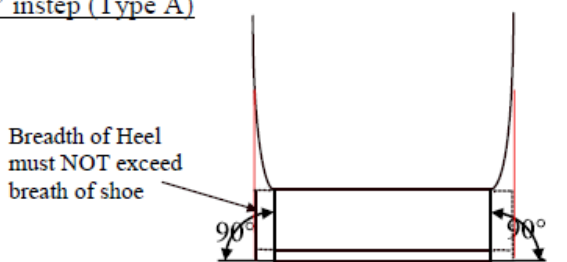

View of heel from the rear of the shoe (Type A and B)

more than 35mm. The “sole plate” must not be metallic and be a minimum of 6.5mm. See illustration below.

Readymade boots can be bought from a starting price of around £80 to £150 depending on build spec. Otherwise they can be made at home with relatively little equipment. 2 examples of inexpensive tug of war boots are given below

1. Leather boots

Purchase a pair of army boots from an army surplus store. Grade 2 boots can be as little as £15. If you have the choice select boots with hard rubber soles rather than soft rubber.

Grind all the grips off the bottom of the boots (safely in a ventilated area using a vice and suitable personal protective equipment).

Get a steel plate no more than 6.5mm thick (take care that the overall heel depth (plate plus heel) will come to no more than 35mm). Draw around the heel on the plate and cut the heel plate out. Smooth the edges off.

Screw and fix the plates to the heel by 4 bolts threaded down from the inside of the boot into the steel plates.

- Take the boot insole out. Drill the holes the correct size for the thread down through the heel and mark the steel plate before drilling the 4 holes through the plate. Tap the thread in the plates so the bolts can screw down through the heel and through the plate. Grind the end of the bolts off so it is flush with the bottom of the plate.
- It is advisable to use washers on the inside of the heel to prevent the bolts being pulled through the heel. Also the use of a strong adhesive will assist a good bond.

Replace the insole.

2. Roller Blade Boots

Purchase a pair of roller blades, not too expensive, but comfortable (there are plenty second hand from online auction sites). Ideally the boots should have one clip at the top and laces down the boot. Make sure also that the wheel carriage is riveted on to the base of the boot and not moulded on.

Unscrew the rollerblade fixings from the sole of the boot or carefully drill them out.

Make a template of the sole of the boot.

Use this template to mark a piece of 8 to 10mm thick black hard Nylon/Teflon/Trespa or similar hard product and cut out with a suitable tool.

Screw this cut-out to the sole of the rollerblade boot. Screws should be fixed from inside the boot downwards into the nylon, and upward through the nylon into the sole, being careful with screw length so not to penetrate the inside of the boot - remember to remove any insoles before fixing.

To create a heel, use 10mm Nylon/Teflon/Trespa or similar hard material. Make a template of the heel section, about 90mm long from the back of the boot.

Cut the nylon heel piece to size and screw to the new nylon sole of the boot.

Using the same heel template, mark and cut a piece of steel with a maximum thickness of 6.5 mm.

Screw onto the heel of the boot.



National Federation of Young Farmers' Clubs (England and Wales)
YFC Centre, 10th Street, Stoneleigh Park, Kenilworth, Warwickshire CV8 2LG

tel 024 7685 7200 fax 024 7685 7229 email post@nyfyc.org.uk web www.nyfyc.org.uk